

# THIS IS THE FUNCTION OF A SALA LOAD ARRESTOR

The load arrestor, connected to a load, will stop a fall should it occur. The load arrestor will not only protect equipment attached to it, but also people and other items under the suspended equipment.

**FUNCTION:** see drawing below.

The load arrestor is attached to a structure via bolt hole (A). Equipment to be protected is to be attached to the wire rope (B). The wire rope is kept under tension and is automatically rewound on the wire rope drum (12). A drum spring will keep the wire rope under tension (15). If a fall occurs, a ratchet pawl (9) will engage with a ratchet ring (18), when the wire speed exceeds 0.5 m/sec. The ratchet ring is then screwed into the cover (4) and compresses the brakedisc (7) until all energy has been absorbed and the equipment safely held, undamaged by the wire rope. The break disc (7) also pushes the indication pin (6) through the cover (4). An indication pin protruding by a few millimetres indicates that the load arrestor should immediately be removed, serviced and have the brake reset.

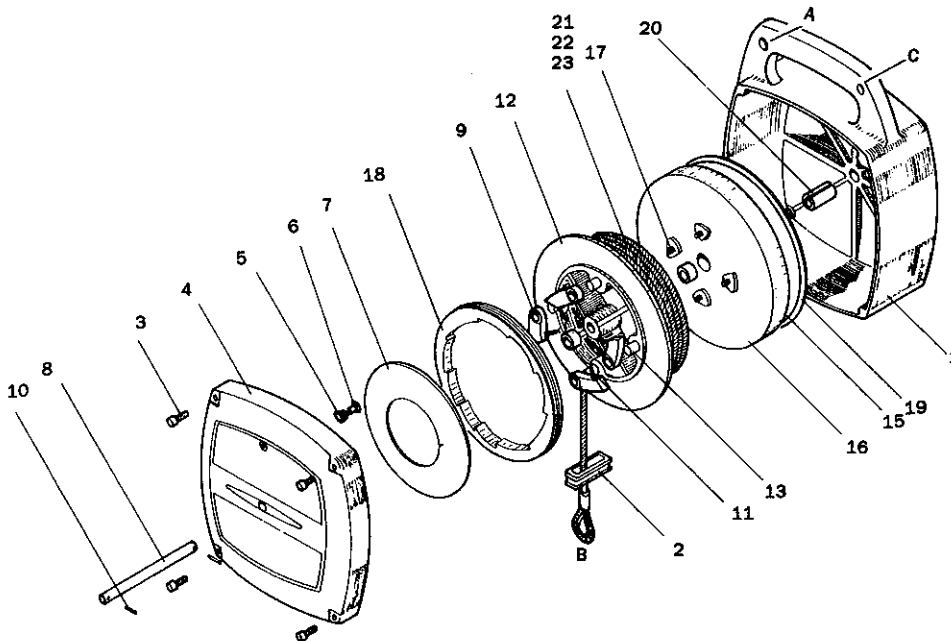

1	Housing	1	46001	13	Stud shaft for ratchet pawl	4	46008
2	Guide bushing	1	46010	14	Bushing for wire drum	2	46005
3	Screw MC 65 6x35	4	46026	15	Drum spring	1	46011
4	Cover with ratchet ring	1	46002	16	Spring housing	1	46006
5	Pressure spring	1	11141	17	Screw MCS 5x16 A2	4	46024
6	Indication pin	1	46020	18	Ratchet ring	1	46003
7	Brake disc	1	46016	19	Non friction disc	1	46014
8	Wire rope drum shaft	1	46007	20	Sleeve	1	46015
9	Ratchet pawl	4	46009	21	Wire rope LA 300	1	47134
10	Expander pin	2	46021	22	Wire rope LA 400	1	47135
11	Ratchet pawl spring	4	47117	23	Wire rope LA 500	1	47137
12	Wire drum complete	1	47163				

# INSTALLATION- AND INSPECTION MANUAL

FOR  
LOAD  
ARRESTOR

LA 300-12  
LA 600-6P  
LA 400-8  
LA 800-4P  
LA 500-5  
LA 1000-2,5P

# INSTALLATION

Attach the load arrestor by bolting a 12 mm nut and bolt through hole A, and an 8 mm nut and bolt through hole C.

The wire rope is connected to the load by using the following sizes of nuts and bolts:

- 12 mm for LA 300-12, LA 600-6P
- 12 mm for LA 400-8, LA 800-4P
- 16 mm for LA 500-5, LA 1000-2,5P

The attachment point should be made with two parallel flanges of 19 mm distance.

Alternatively a shackle can be used, using attachment hole A.

When properly installed -  
PULL OUT THE WIRE ROPE AND LET IT SLOWLY RETRACT.

Anchoring points should be calculated for a minimum breaking strength corresponding to the wire rope used.

**TABLE 1**

LA 300-12	min. 15.8 kN
LA 400-8	min. 22.8 kN
LA 500-5	min. 31.0 kN

Ensure that the load is in line with attachment hole A. If the Load Arrestor is to be installed where the load is NOT HELD VERTICALLY during hoisting or lowering, this should be discussed with your Sala representative before installation.

When the wire rope is pulled out, the last part is painted red.

**THE RED PART SHOULD NEVER BE PULLED OUT OF THE LOAD ARRESTOR.**

When installing outdoor please call the Sala representative for discussion about protecting the unit from icing, by example the use of a heating hood.

The load arrestor can be combined with a pulley and can if properly installed, protect twice the nominal load but with half wire length capacity.

The load arrestor must for this application be ordered complete with pulley and modified ratchet pawl springs to maintain engagement speed of 0.5m/s.

The wire rope should move in the same direction on both the wire drum and the external pulley. ▶

The anchor point must for this application be calculated as follows:

**TABLE 2**

LA 600-6P	min 15.8 kN x2 = 31.6 kN
LA 800-4P	min 22.8 kN x2 = 45.6 kN
LA 1000-2,5 P	min 31.0 kN x2 = 62.0 kN

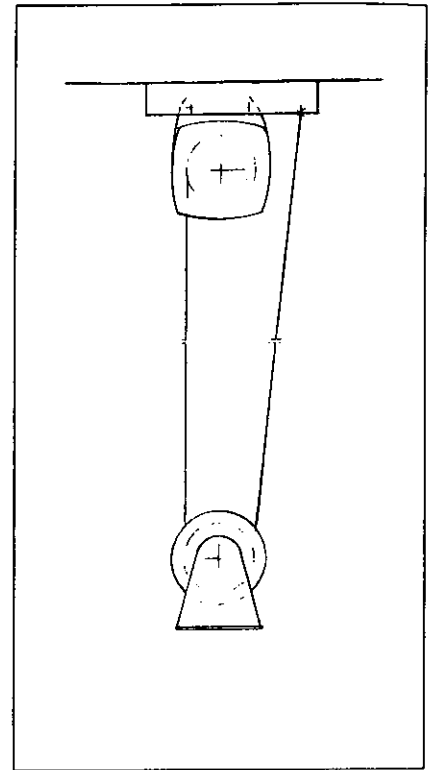

The Load Arrestor can be used in cramped conditions by using a pulley as shown below. The load arrestor must under all circumstances be installed so that the wire drum is working vertically.

For this application the anchorage for the external pulley must be calculated according to TABLE 2. ▼

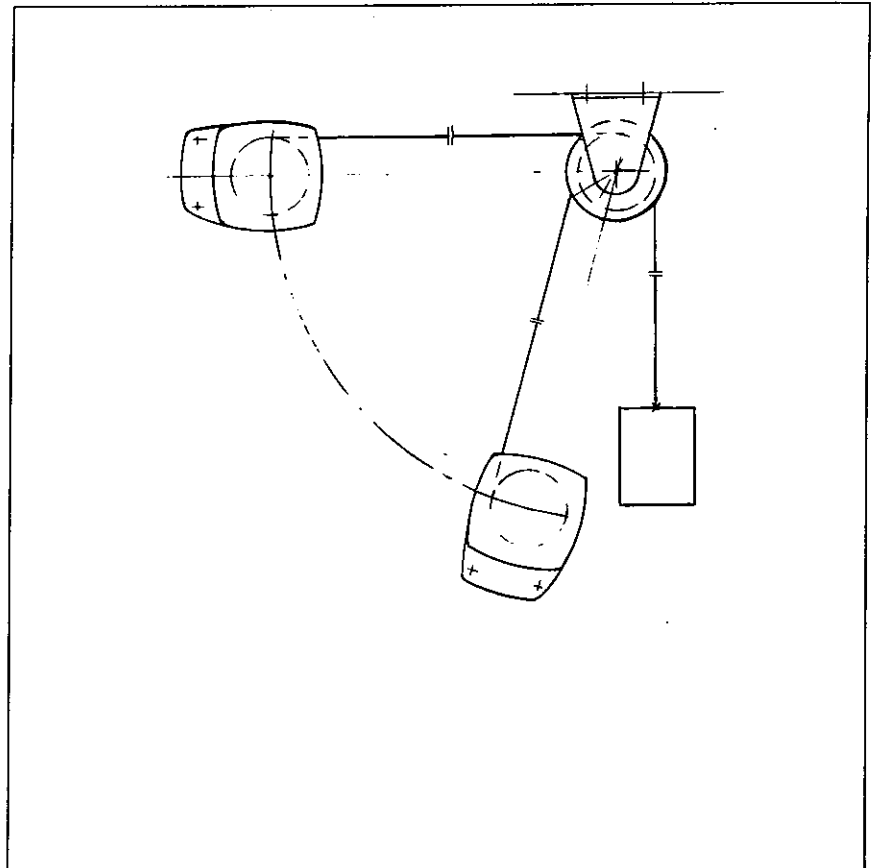

A load can under special circumstances be secured by two load arrestors. PLEASE CONTACT SALA REPRESENTATIVE BEFORE MODIFYING INSTALLATION PROCEDURE.

As the ratchet pawls will not engage simultaneously in two load arrestors, it is vital that the Load Arrestor are installed at a sufficient distance apart with unre-

stricted vertical movement under each unit to enable the falling force to be properly divided between them.

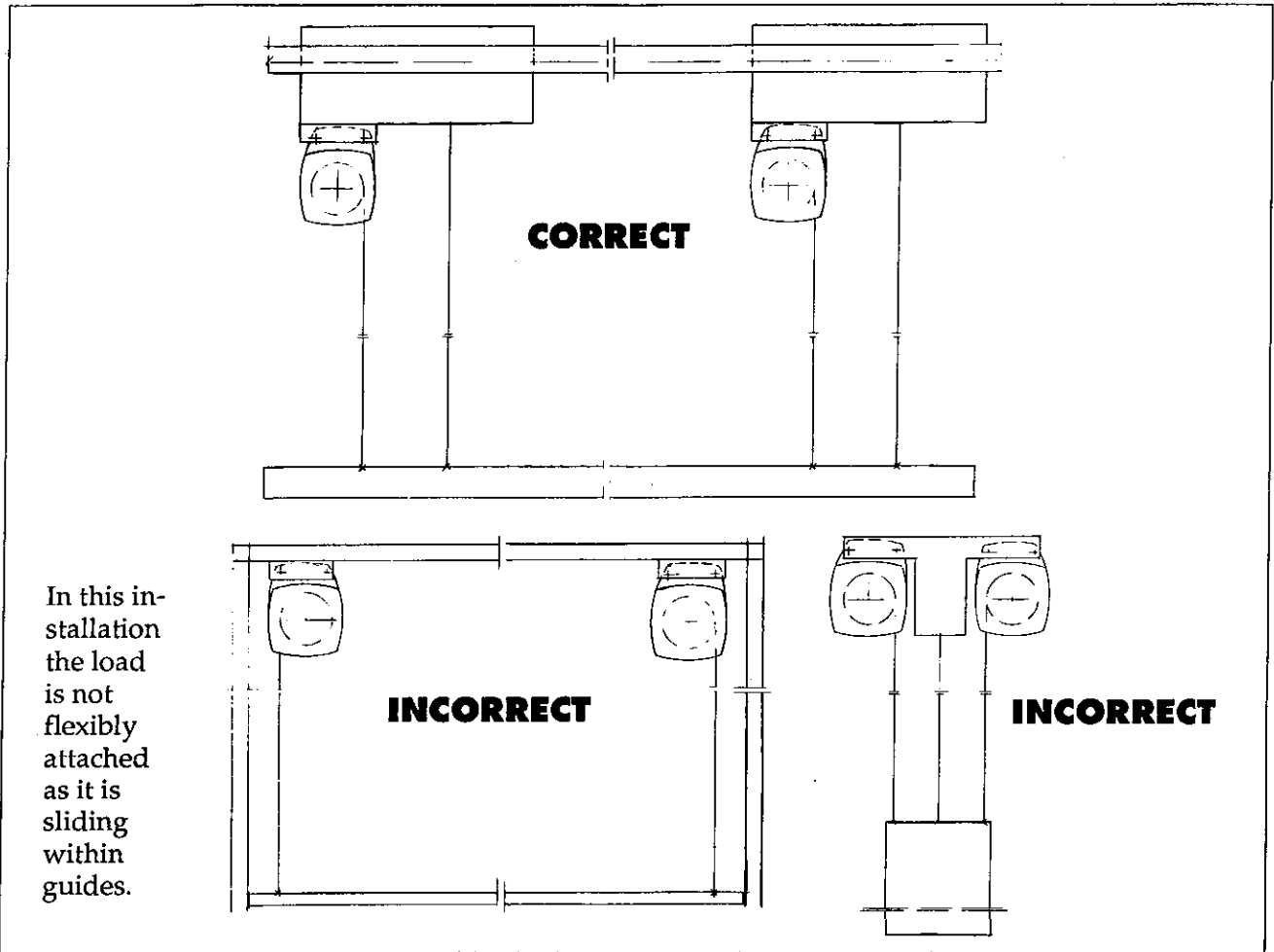

## INSPECTION

- Check the break mechanism by pulling the wire rope
- Pull out the entire wire rope to check for damages. If a thread is broken, replace the wire. Let the wire rope retract carefully. The Load Arrestor can be damaged if the wire rope is allowed to retract without resistance
- Check the red indicator pin. If it protrudes remove the load arrestor from service, check and service the unit and reset the break.

## SERVICE

Service must always be undertaken by an authorized service depot or by authorized personnel. Test certificate/reports to be issued.

## INSPECTION - INTERVAL OF SERVICE

Inspection to be done annually, ev. more often dependent on environmental conditions.

### SERVICE MUST BE DONE:

- After a fall
- Thread breakages in wire rope
- When corrosion or heavy dirt penetration is suspected, thus not more than two years interval.

**DIMENSION DRAWING**

