

PROTECT
PERSONNEL,
VALUABLE
EQUIPMENT
AND
MATERIALS.



PROTECT PERSONNEL, VALUABLE EQUIPMENT AND MATERIALS.

DBI-SALA's range of Load Arrestors are designed as backup devices used to arrest the accidental fall of heavy objects such as doors, automotive assembly line tools or even elevators.

LOAD ARRESTORS

DBI SALA's range of Load Arrestors are backup safety devices used in conjunction with lifting equipment such as cranes and hoists. The Load arrestor provides independent protection that will arrest the fall of a load in the event of the primary system failing. Being completely independent of the primary lifting system it reduces the risk of equipment damage and protects personnel in and around the danger zone. Note: This device is used for restraining material only, it is not intended for use on personnel.

The devices are engineered to completely stop a dropping load in the event of a failure of the primary lifting device that allows the load to fall or descend too quickly. The arrestor senses a descent speed in excess of 0.5m/sec and automatically engages an internal inertia-activated mechanical brake that acts on the rope drum. This decelerates and stops the lowering of the suspended load within approximately 1m and absorbs the shock forces.

The load arrestor is installed adjacent to the primary lifting device and fixed to a suitable anchorage point. Its retractable steel cable is then secured to the load. The wire rope is attached to the arrestor via an internal spring loaded drum that keeps the rope under a constant light tension, yet allows unrestricted movement of the protected load. By using a pulley, the load can be doubled at the expense of the active cable length. Precautions must be taken to ensure that minimum anchorage point requirements are met. The 3700801 model comes complete with a pulley that is utilised to achieve its rated capacity.



3700300



3700801

FEATURES

- Designed as a backup device to completely stop a dropping load if it breaks free
- Inertia activated brake with indicator button engages in the event of a fall, absorbing energy and stopping the fall within centimetres
- Energy absorbing system offers added safety and security for the attached equipment and personnel below
- Self retracting galvanised cable automatically extends and retracts as the equipment moves towards or away from the device, keeping the lifeline taut at all times.
- Portable self contained unit that is easy to install and stores the entire lifeline within the housing
- Robust durable design heavy duty aluminium construction for added durability and longevity.
- Protects loads from 300kg up to 800kg
- Meets or exceeds all applicable industry standards

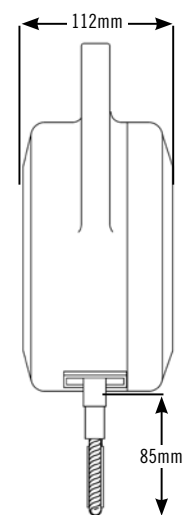
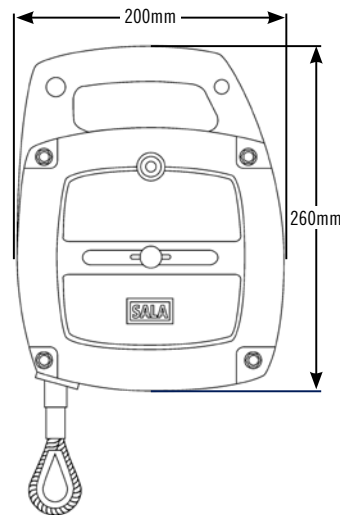

Specifications:

Part Number	Lifeline		Maximum Load	Min Breaking Strength	Max. Stopping Distance	Weight (approx.)
	Length	Diameter				
3700300	12m	5mm	300kg	16kN	0.6m	8.4kg
3700400	8m	6mm	400kg	23.1kN	0.6m	8.4kg
3700501	5m	7mm	500kg	31.4kN	0.6m	8.4kg
3700801	4m	6mm	800kg	23.1kN	0.4m	10.8kg

Lifeline Material: 7x19 galvanised aircraft wire rope. **Main Shaft:** Zinc Plated Steel. **Locking Pawls:** Zinc Plated Steel. **Motor Springs:** Carbon Steel. **Cable End Termination:** Swaged thimble eye. **Brake Activating Speed:** 0.5m/s. **Pulley:** Galvanised Steel. **Housing:** Cast aluminium. **Finish:** Polyester Baked Paint. **Standards:** Tested on behalf of DBI-SALA by National Engineering Laboratory (Glasgow). **Country of Origin:** United Kingdom. **Special Instructions/Conditions of Use:** Reading user instruction manual prior to use is essential.



Capital Safety - Australia & New Zealand
Australia: 1800 245 002 | New Zealand: 0800 212 505
www.capitalsafety.com.au
sales@capitalsafety.com.au

